

APM Buildings

easy-n-affordable

1-800-296-6161 www.apmbuildings.com

What's Next - Pole Buildings

Thank you for choosing to price your building through APM Buildings. We at APM Buildings understand the process of selecting, purchasing and erecting your building and keeping satisfied customers. We help you follow a path to make it an easy, step by step process right through completion.

Summary Steps

1. Use our quote system to select the right building for your budget.
2. We then design your building with the options you chose in your estimate.
3. We provide plans - to get your permits from municipalities / local governments.
4. We provide plans - for your building inspector to approve.
5. The building is put into production once all of the above is satisfied.
6. We provide a pre-delivery checklist (delivery, safety, construction notes etc.)
7. We deliver the building with a complete set of plans.
8. We are available though-out the construction process for any issues.

We have one of the most 'easy n affordable' building systems in the industry today. We will design your building with all of the options that you have chosen from your estimate. Once this is complete and you are satisfied with the design, we will supply you with many important documents (see 'Design Permitting - Sample') next page, pages; this includes pole layout, wall girts (north, south, east, west), purlin / truss / fascia layout, cross section detail, overhang detail, steel wall layout (north, south, east, west), roof steel layout, steel component application, truss design, etc. To get started with this step, we require a 20% deposit towards the purchase of your building.

We encourage you to take all of these documents to get approval / permit from you local municipality or governing agency. Once you get your permit, we encourage you to get approval from your building inspector to make sure no further paper work is required. If your local municipality or governing agency requires more information, we can generally supply the information needed at no additional charge. However, if you are required to get engineered stamped drawings, we can facilitate this for you, the cost will depend on the size & scope of your building.

Once the above is finalized, your building can be placed on order and into production, with final payment before delivery. Lead times are generally 2-3 weeks.

Thanks again for taking the time to consider APM Buildings for your next building project.

Sincerely,
APM Buildings Team

APM Buildings

easy-n-affordable

1-888-261-2488 www.apmbuildings.com

Design / Permitting - Sample

Once you have made the decision to move forward with your building, we will begin with the next step; which is the Design / Permitting process. This is one of the most important steps in the building project. This allows for you view all of your building specs and elevation drawings, perspective views, etc., plus we give you all of the documents needed to get your building permit. The last thing we want is for you to order a building and have us deliver it and for some reason, you are stopped by your local building inspector or governing agency for lack of some document or building code. To get started, we require a 20% deposit, which goes toward the price of your building.

Included in this PDF are samples of what you would receive:

- Prospective Drawing
- Pole Layout
- Elevation Drawings:
 - North
 - South
 - East
 - West
- Purlins / Truss / Fascia Layout
- Cross Section Detail
- Overhang Detail
- Steel Wall Layout
 - North
 - South
 - East
 - West
- Roof Steel Layout
- Steel Component Application
- Truss Design - Drawing
- Post Uplift - System

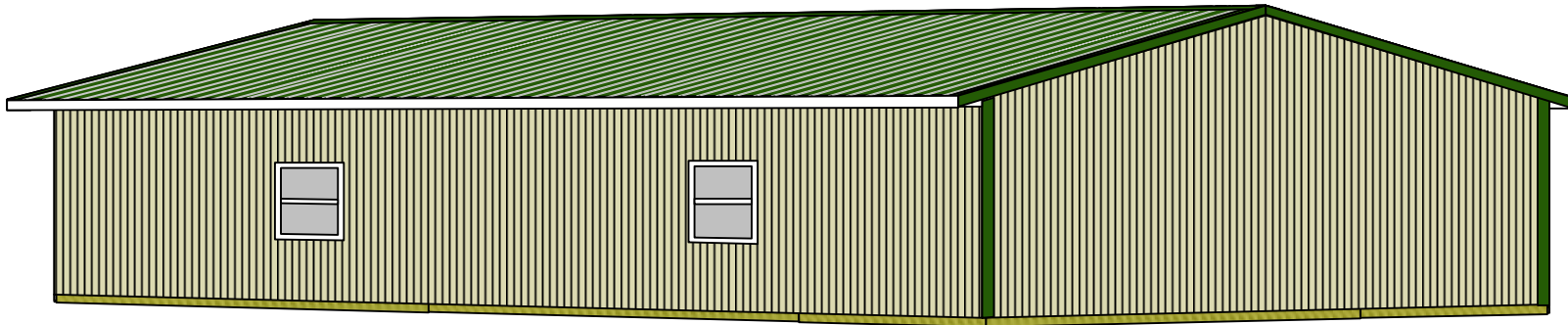

Pole Building
Estimate Number: 4992
12/2/2010

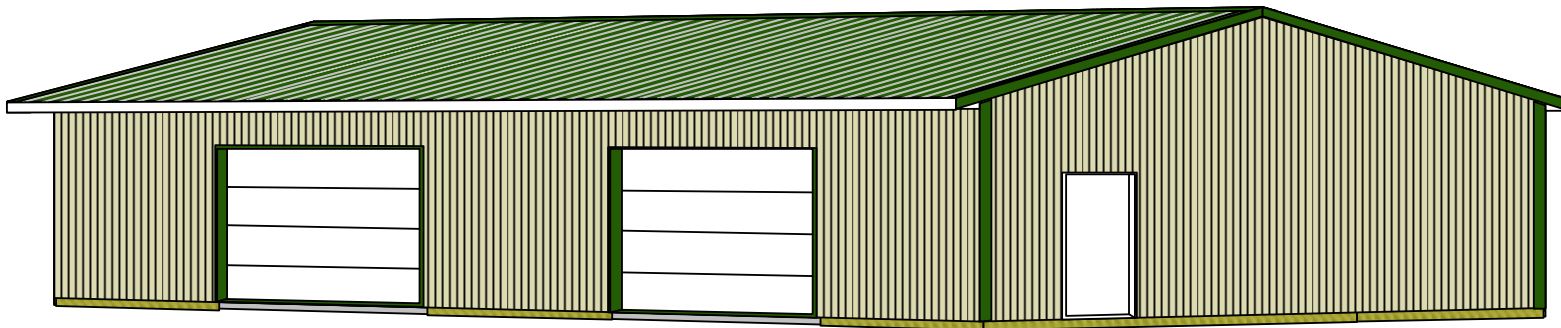

Pole Building
Estimate Number: 4992
12/2/2010



NORTH SIDE-EAVE SIDE 2 ELEVATION





SOUTH SIDE-EAVE SIDE 1 ELEVATION

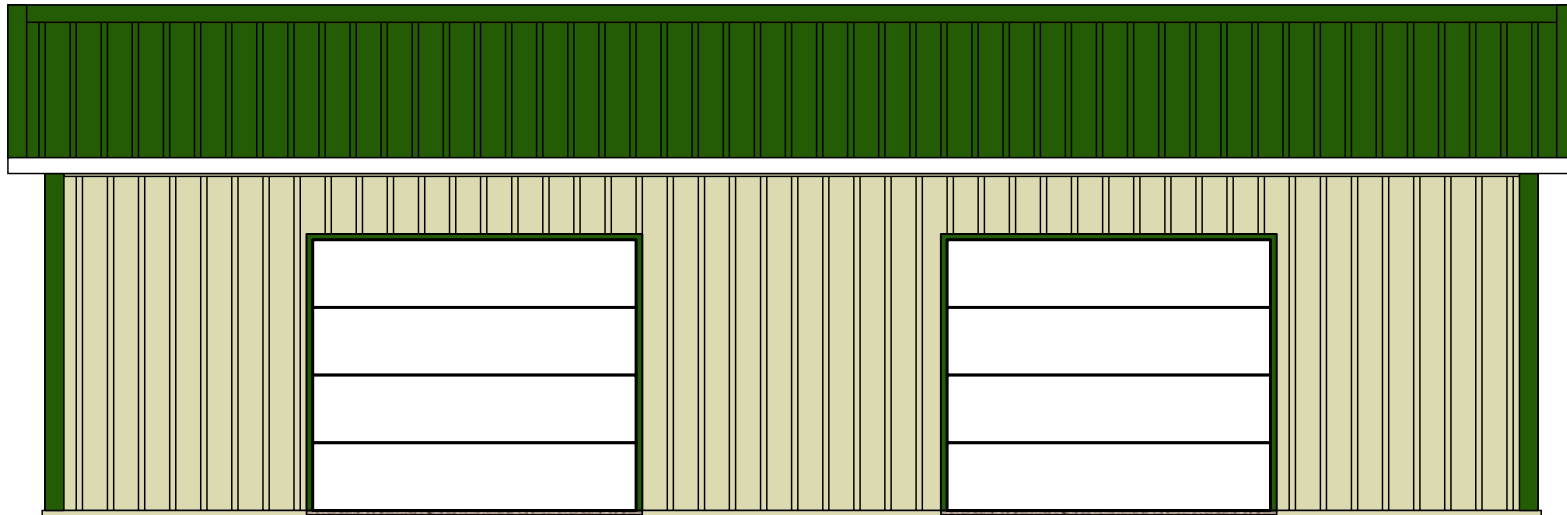



WEST SIDE-GABLE SIDE 2 ELEVATION

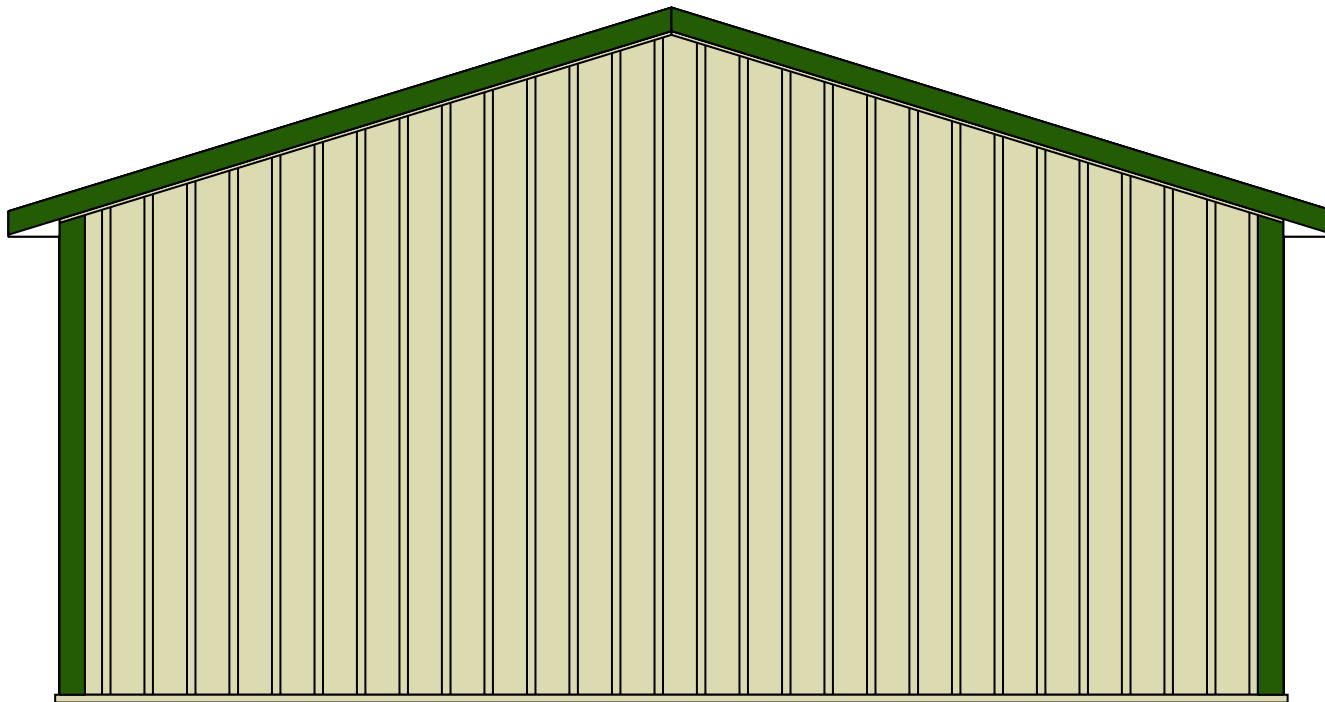

Pole Building
Estimate Number: 4992
12/2/2010



EAST SIDE-GABLE SIDE 1 ELEVATION

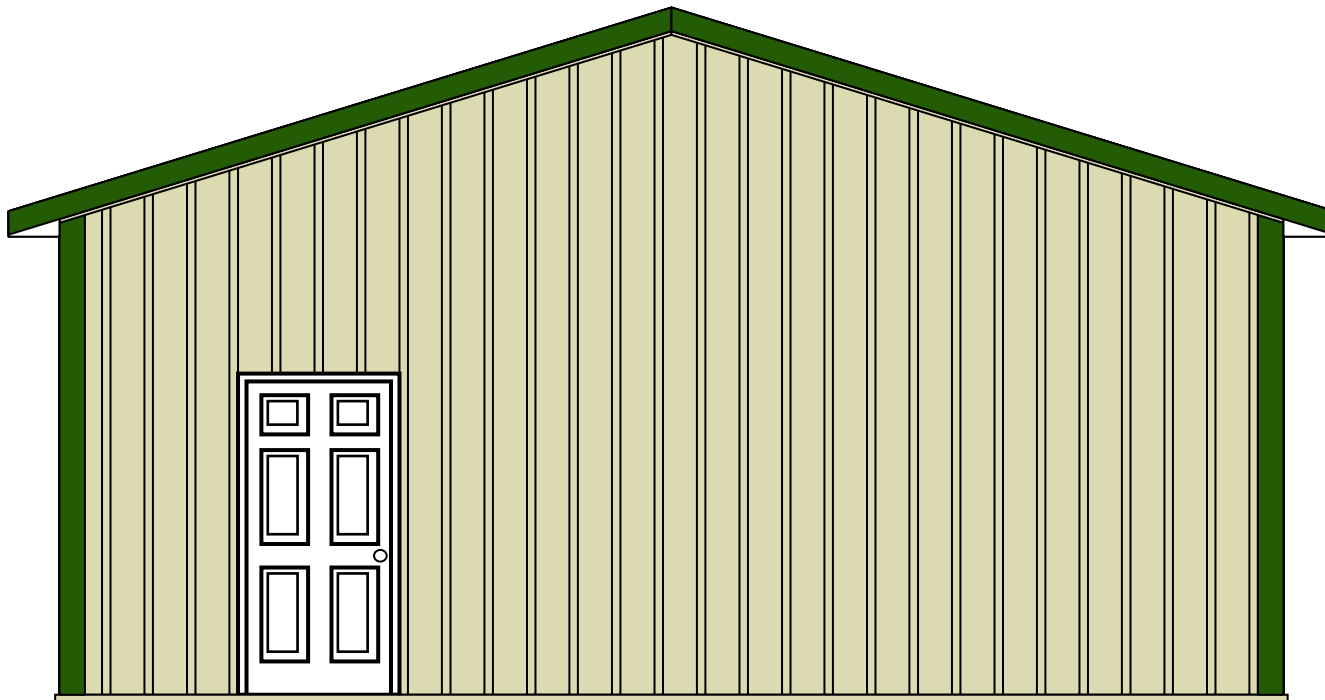

Pole Building
Estimate Number: 4992
12/2/2010

Overhang Detail

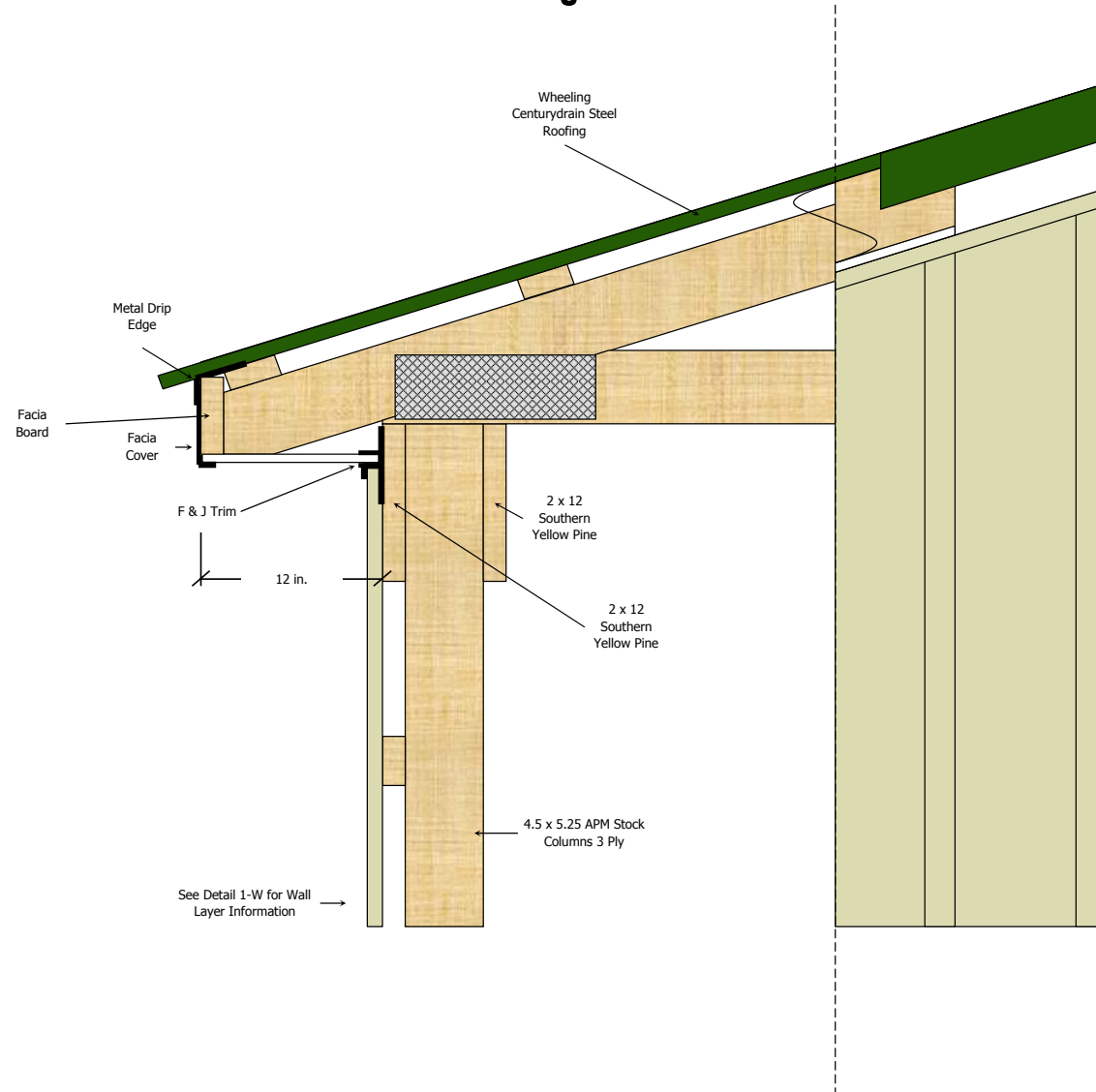

Cross Section Detail

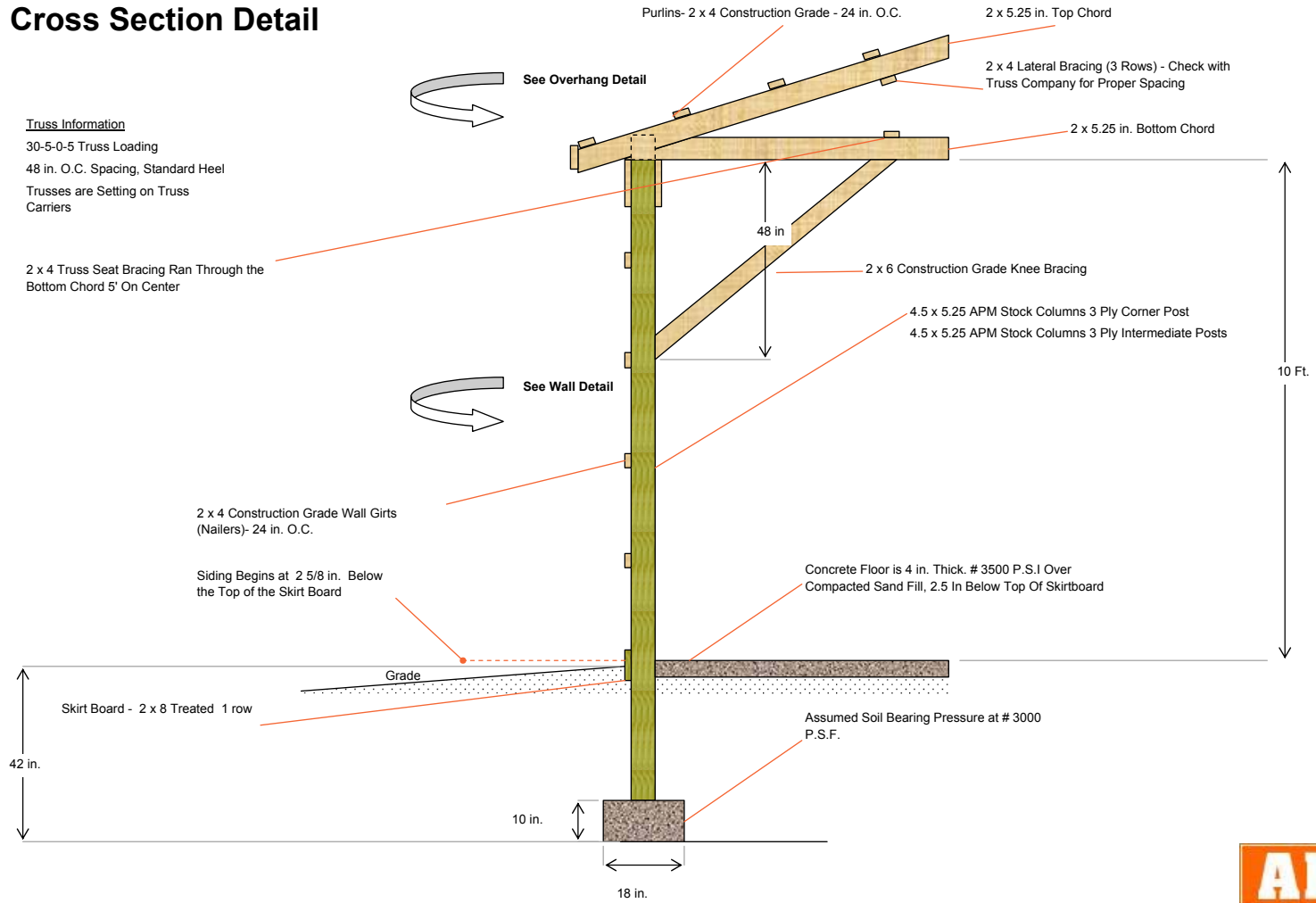



POLE LAYOUT

Personal Use, 960 sq. ft.



Eave 1

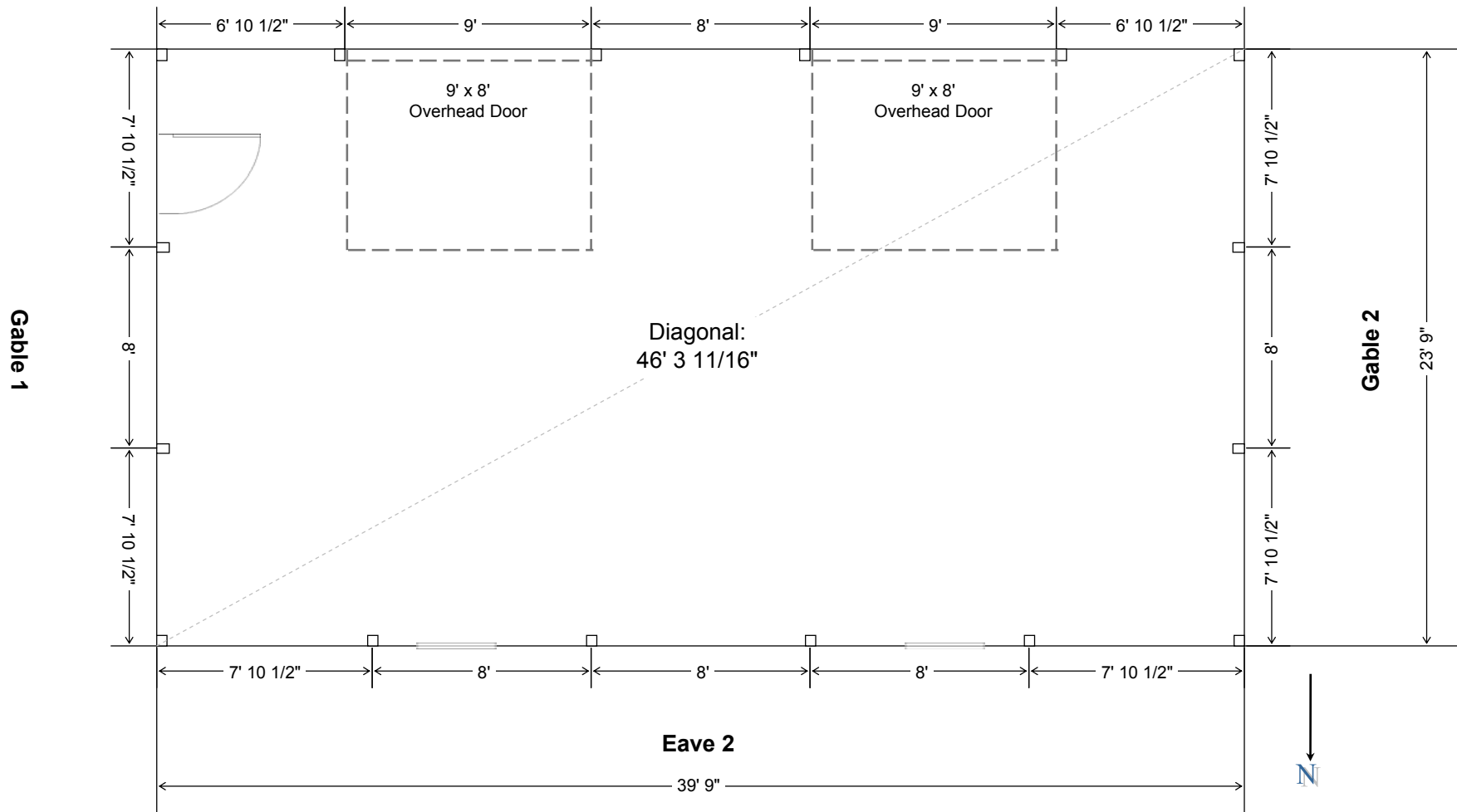



NORTH SIDE-EAVE SIDE 2 WALL GIRT VIEW

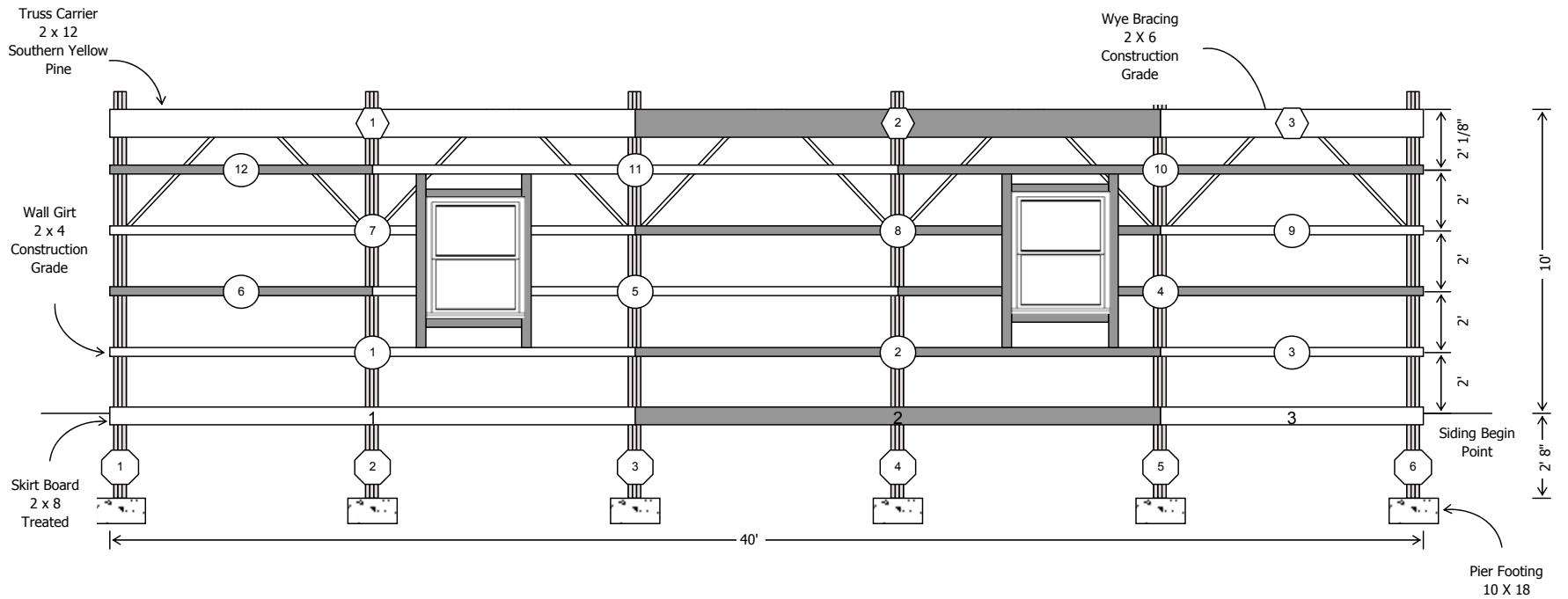



SOUTH SIDE-EAVE SIDE 1 WALL GIRT VIEW

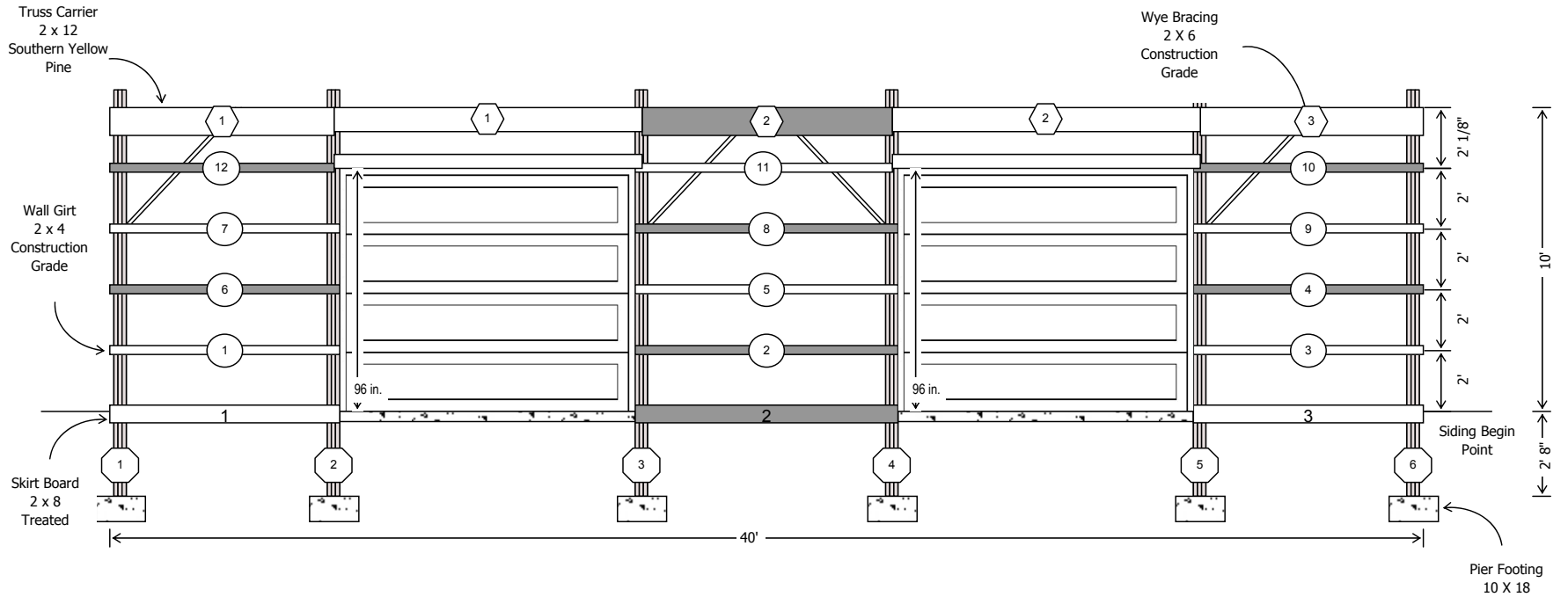



WEST SIDE-GABLE SIDE 2 WALL GIRT VIEW

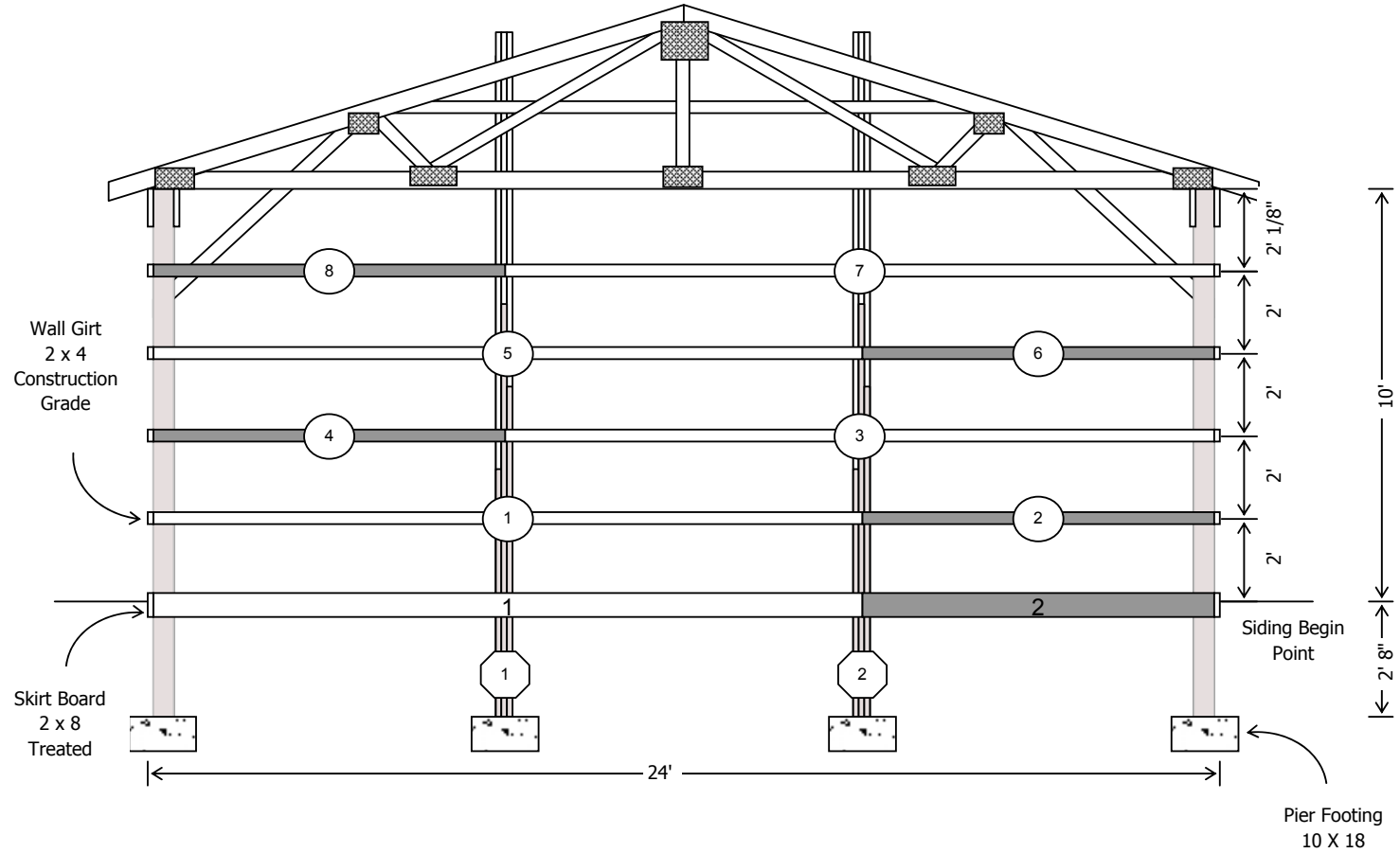



EAST SIDE-GABLE SIDE 1 WALL GIRT VIEW

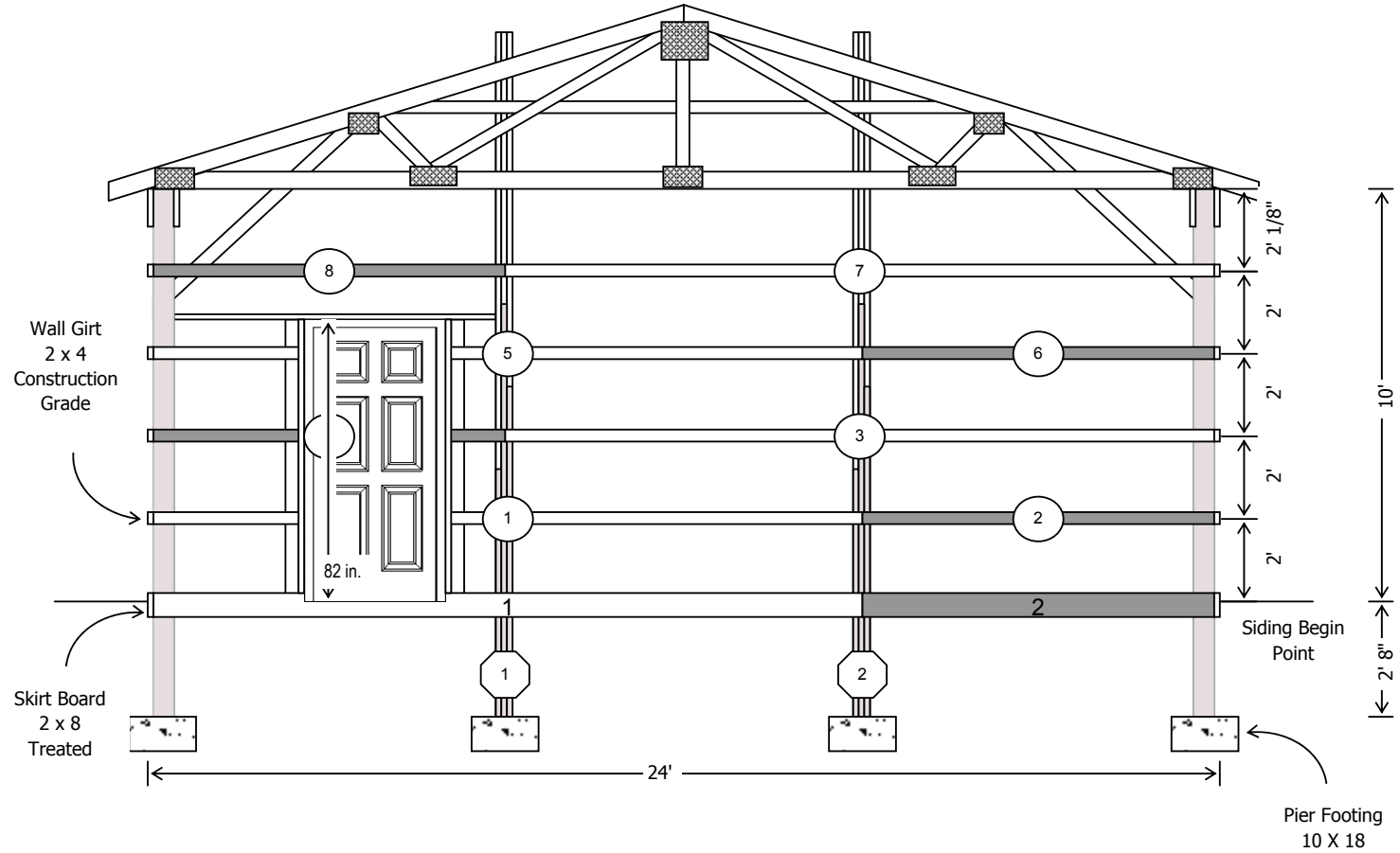



NORTH SIDE-EAVE SIDE 2 TRUSS AND PURLIN LAYOUT

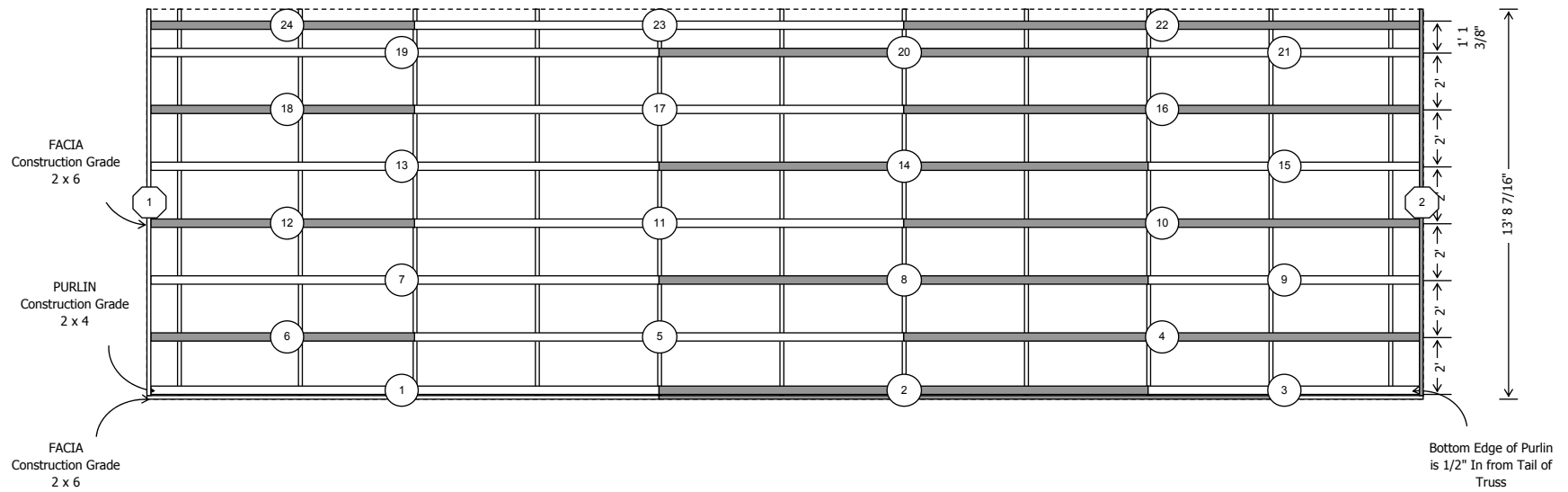



SOUTH SIDE-EAVE SIDE 1 TRUSS AND PURLIN LAYOUT

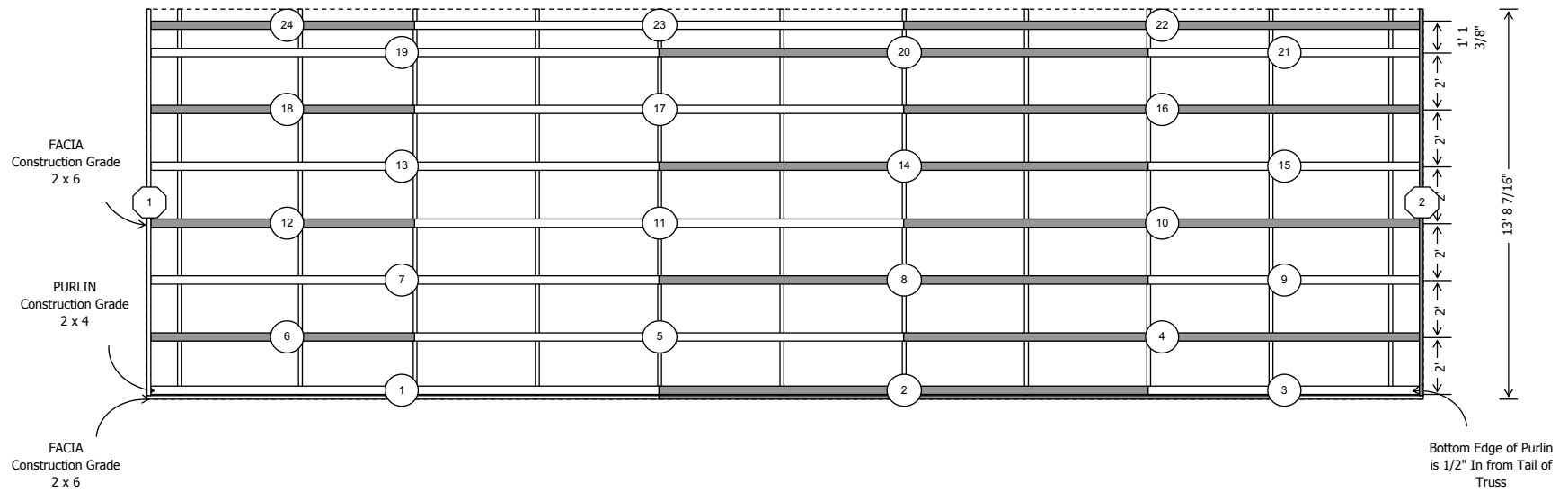



NORTH SIDE-EAVE SIDE 2 ROOF PANEL LAYOUT

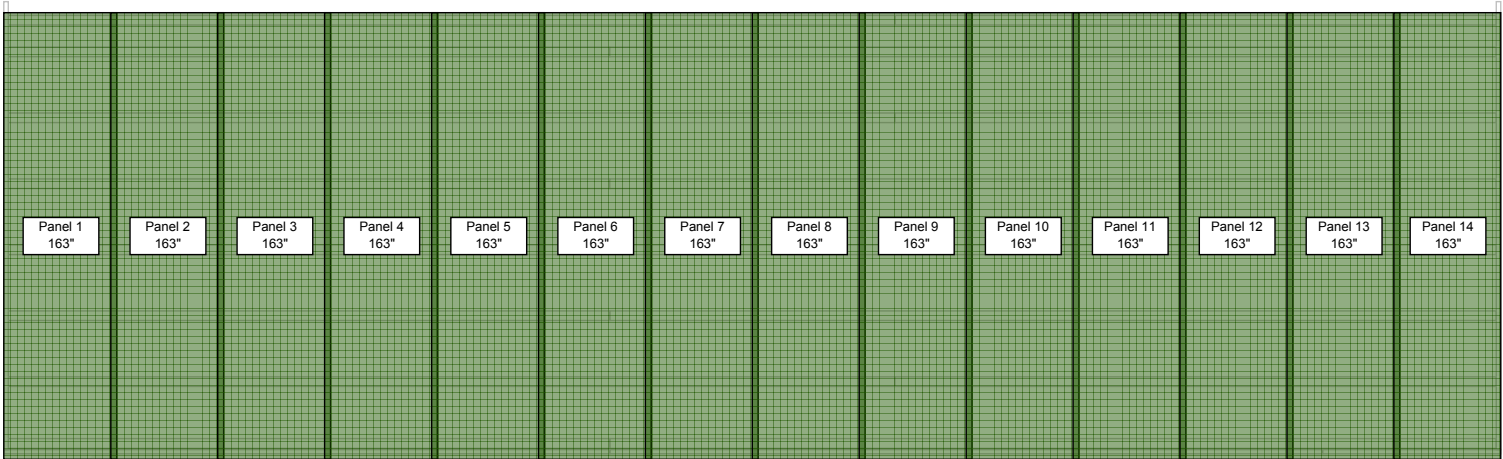



SOUTH SIDE-EAVE SIDE 1 ROOF PANEL LAYOUT

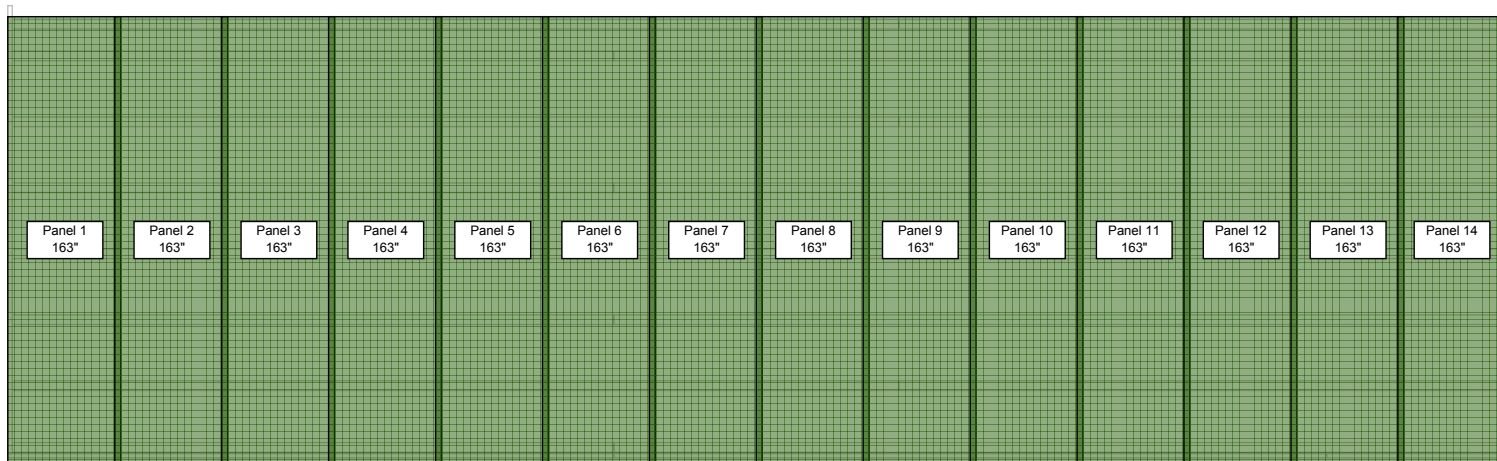



NORTH SIDE-EAVE SIDE 2 STEEL WALL LAYOUT

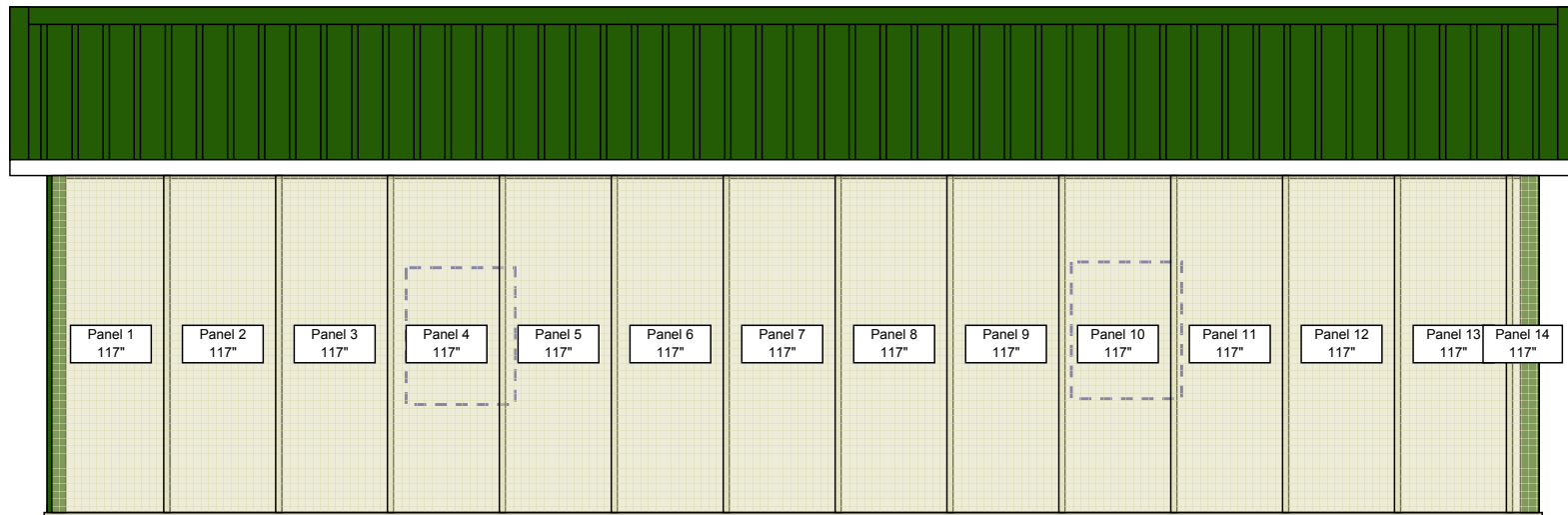

Shift the vertical starting point of the first panel to 1 1/2 in. from the outside corner of the building so there is no panel rib & steel corner trim conflict at the other end. The rib spacing will also be balanced.



SOUTH SIDE-EAVE SIDE 1 STEEL WALL LAYOUT

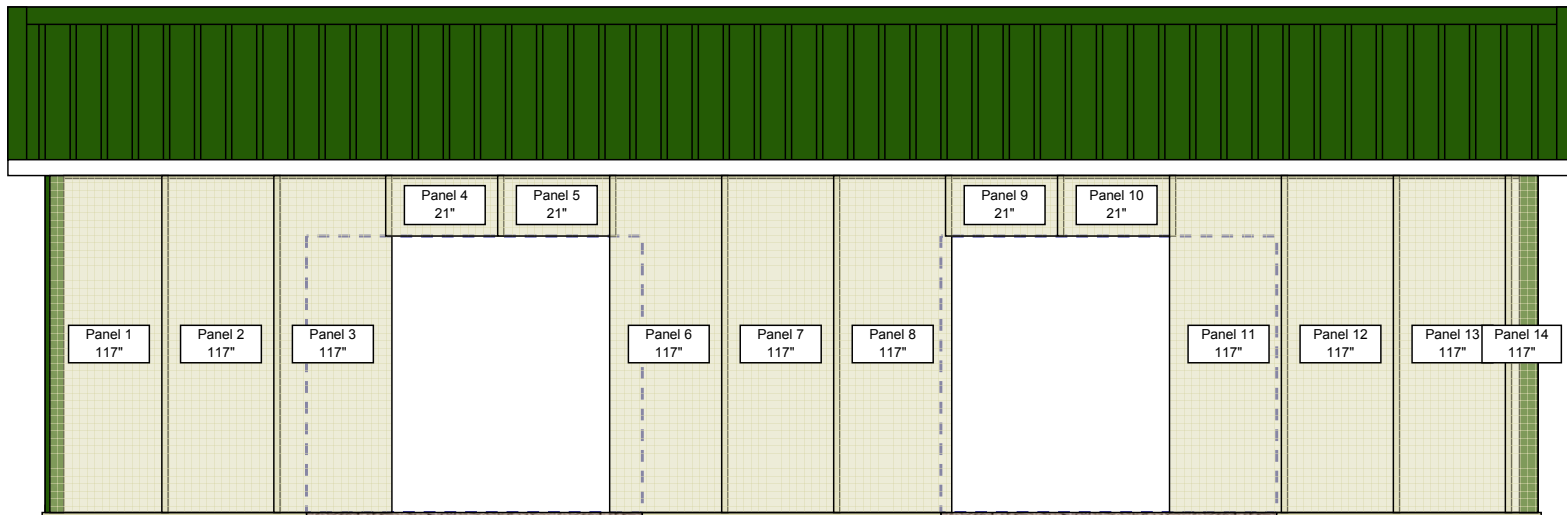

Shift the vertical starting point of the first panel to 1 1/2 in. from the outside corner of the building so there is no panel rib & steel corner trim conflict at the other end. The rib spacing will also be balanced.



WEST SIDE-GABLE SIDE 2 STEEL WALL LAYOUT

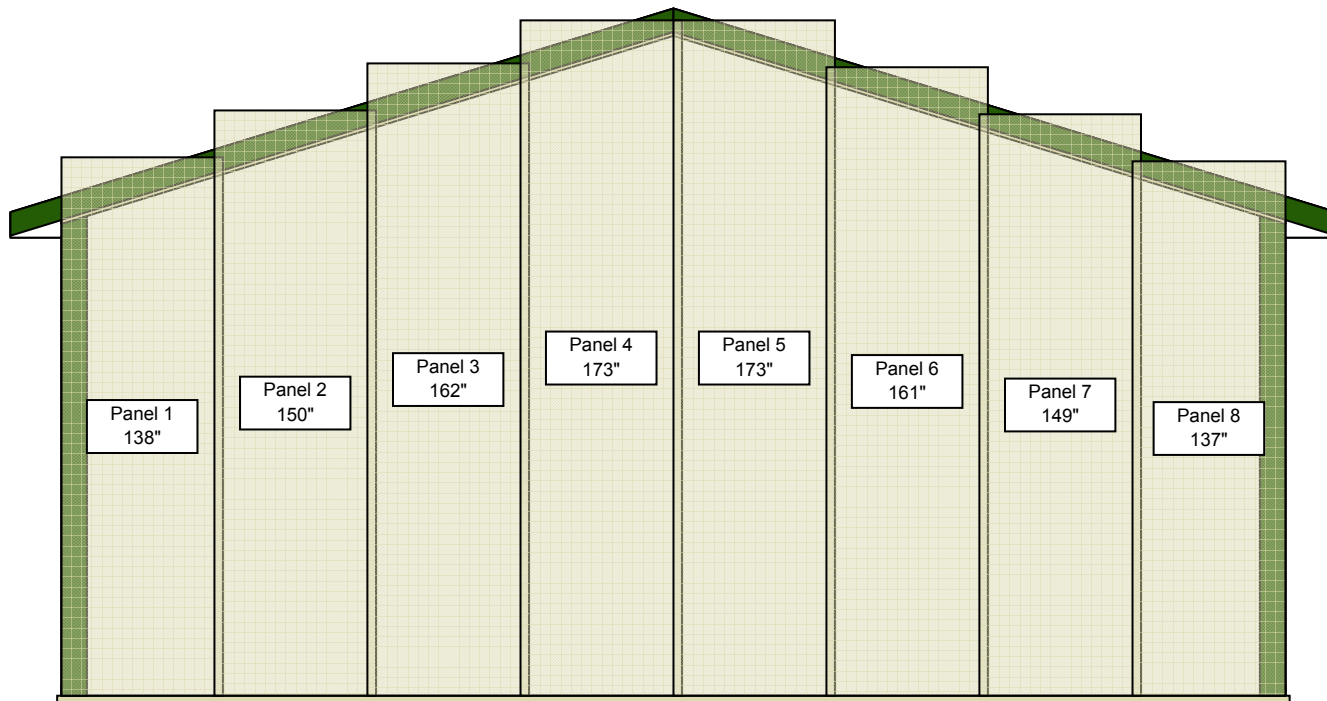

Pole Building
Estimate Number: 4992
12/2/2010



EAST SIDE-GABLE SIDE 1 STEEL WALL LAYOUT

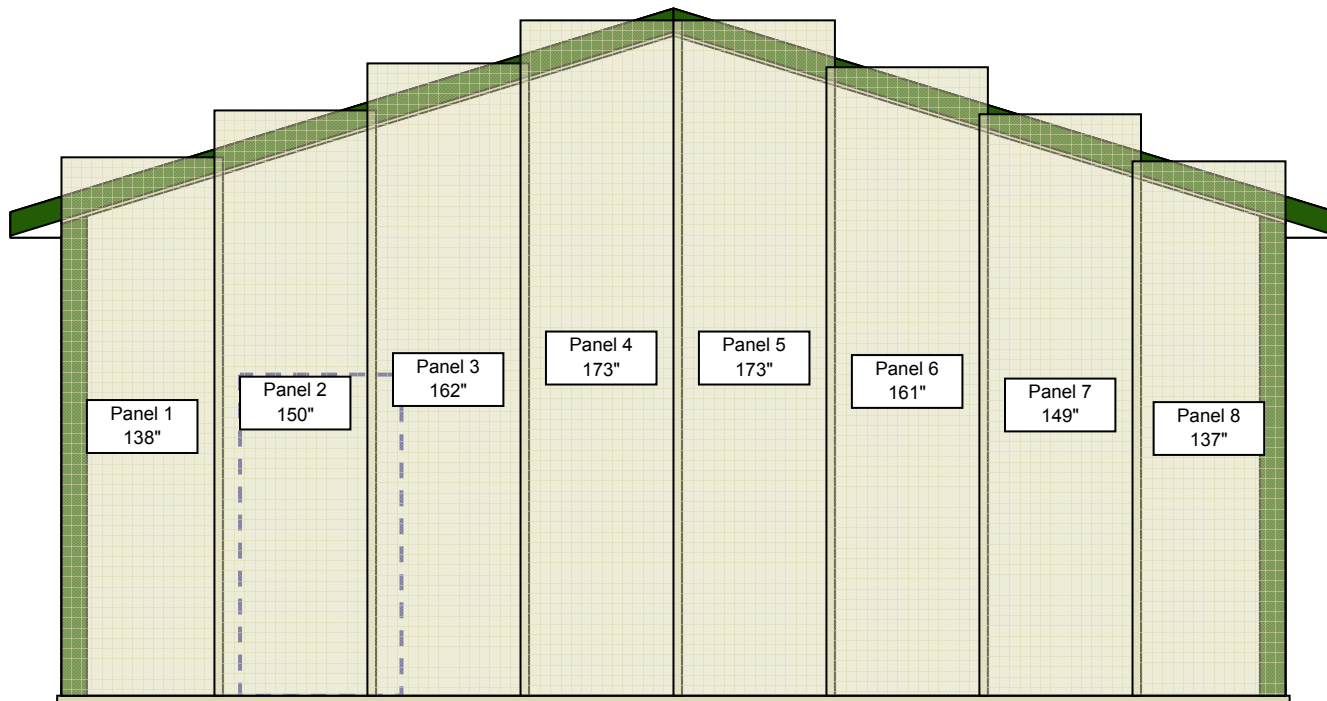

Pole Building
Estimate Number: 4992
12/2/2010

